

LED AREA LIGHT - MEDIUM (XAM)

U.S. and international patents pending

APPLICATIONS

- Recommended for 16 to 24-foot mounting heights
- Three distributions - Types 2, 3, and 5

PRODUCT HIGHLIGHTS

- Technologically advanced solid-state LED lighting designed for 60,000+ hours of maintenance-free operation. Significant energy saving is realized over HID luminaires.
- Exceptional uniformity creates bright environment at lower light levels.
- Improved backlight cutoff minimizes light trespass.
- Light weight makes for easy installation.

LEDs - Select high-brightness LEDs

HOUSING - Housing is die-formed aluminum. Weather-tight housing contains factory prewired driver and field connections. Wiring access door is located underneath and utilizes "toolless" thumbscrew fastener.

OPTICAL UNIT - Lens is clear, flat tempered glass, sealed to aluminum optics housing to create an IP65 rated, sealed optical unit.

MOUNTING - Tapered rear design allows fixtures to be mounted in a quad pattern without the need for extension arms.

ELECTRICAL - Universal frequency power supply (50/60 Hz). Supply voltage must be specified for use with optional button-type photocells.

LIGHT OUTPUT - Lumens noted below in ordering chart by distribution. Input power of 135 watts.

OPERATING TEMPERATURE - -40°C TO +50°C. (-40°F TO +122°F).

DRIVER - State-of-the-Art driver technology designed specifically for LSI LED light sources provides unsurpassed system efficiency. Components are fully encased in potting material for moisture resistance. Driver and luminaire are ETL listed for wet location per UL 1598. Driver complies with IEC and FCC standards.

FINISH - Fixtures are finished with LSI's DuraGrip[®] polyester powder coat finishing process. The DuraGrip finish withstands extreme weather changes without cracking or peeling, and is guaranteed for five full years. Standard colors include bronze, black, platinum plus, buff, graphite, satin verde green, metallic silver and white.

WARRANTY - LSI LED fixtures carry a limited 3-year warranty.

PHOTOMETRICS - Application layouts are available upon request. Contact LSI Applications Group at lighting.apps@lsi-industries.com

SHIPPING WEIGHT - 28.0 lbs (12.7 kg)

LISTING - ETL listed to U.S. and Canadian safety standards.



Suitable for wet locations

IP65



DIMENSIONS

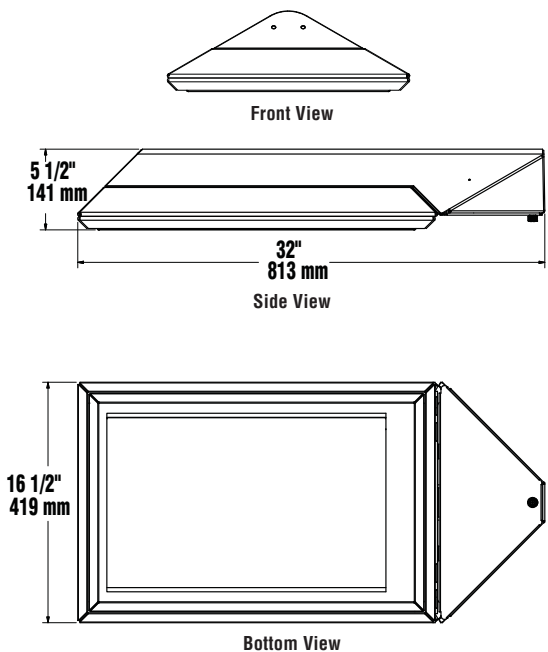

LUMINAIRE ORDERING INFORMATION

TYPICAL ORDER EXAMPLE: **XAM 2 LED 119 CW UE WHT PCI120**

Prefix	Distribution	Light Source	# of LEDs	LED Color Temperature	Line Voltage	Luminaire Finish	Options
XAM - LED Area Medium	2 - Type 2 9996 lumens 3 - Type 3 8300 lumens 5 - Type 5 9520 lumens	LED	119	CW - Cool White (5000°K nom.)	UE - Universal Voltage (120-277)	BLK - Black BRZ - Bronze BUF - Buff GPT - Graphite MSV - Metallic Silver PLP - Platinum Plus SVG - Satin Verde Green WHT - White	Button Type Photocells PCI 120 - 120v PCI 208 - 208v PCI 240 - 240v PCI 277 - 277v

LUMINAIRE EPA CHART ² - XAM	
	Single 1.2
	D180° 2.4
	D90° 2.0
	T90° 3.4
	TN120° 3.4
	Q90° 4.0

ACCESSORY ORDERING INFORMATION (Accessories are field installed)	
Description	Order Number
BKA-6-XBO-EC-6-CLR 6" Extension Arm	382136CLR ¹
XAM House Side Shield (for Types 2 & 3)	consult factory
X4RPP Round Pole Plate for 4" Poles	379967CLR ¹
X5RPP Round Pole Plate for 5" Poles	379968CLR ¹

NOTES:

- 1- Replace "CLR" with desired color (ex. 382136BRZ)
- 2- House Side Shield adds to fixture EPA. Consult factory.